

# INSTRUMENTATION ENGINEERING

## MEASUREMENTS



Comprehensive Theory  
*with Solved Examples and Practice Questions*





### **MADE EASY Publications Pvt. Ltd.**

**Corporate Office:** 44-A/4, Kalu Sarai (Near Hauz Khas Metro Station), New Delhi-110016 | **Ph. :** 9021300500

**Email :** infomep@madeeasy.in | **Web :** www.madeeasypublications.org

## **Measurements**

Copyright © by MADE EASY Publications Pvt. Ltd.

All rights are reserved. No part of this publication may be reproduced, stored in or introduced into a retrieval system, or transmitted in any form or by any means (electronic, mechanical, photo-copying, recording or otherwise), without the prior written permission of the above mentioned publisher of this book.



**MADE EASY Publications Pvt. Ltd.** has taken due care in collecting the data and providing the solutions, before publishing this book. In spite of this, if any inaccuracy or printing error occurs then **MADE EASY Publications Pvt. Ltd.** owes no responsibility. We will be grateful if you could point out any such error. Your suggestions will be appreciated.

## **EDITIONS**

- First Edition : 2015
- Second Edition : 2016
- Third Edition : 2017
- Fourth Edition : 2018
- Fifth Edition : 2019
- Sixth Edition : 2020
- Seventh Edition : 2021
- Eighth Edition : 2022
- Ninth Edition : 2023
- Tenth Edition : 2024
- Eleventh Edition : 2025
- Twelfth Edition : 2026**

# CONTENTS

## Measurements

### CHAPTER 1

#### Introduction ..... 2-26

1.1	Measurements and its Significance.....	2
1.2	Types of Instruments.....	3
1.3	Deflection and Null Type Instruments.....	3
1.4	Errors in Measurements and their Analysis.....	8
1.5	Types of Errors.....	14
1.6	Analog Instruments.....	15
1.7	Torques in Electromechanical indicating Instruments.....	17
1.8	Types of Damping.....	18
1.9	Errors in Meters.....	20
1.10	Important Prefixes and Their Symbols.....	21
	<i>Objective Brain Teasers</i> .....	22
	<i>Conventional Brain Teasers</i> .....	25

### CHAPTER 2

#### Measurement of Resistance..... 27-52

2.1	Resistors.....	27
2.2	Methods of Reducing Residual Inductance and Capacitance in Resistors.....	28
2.3	Measurement of Low Resistance.....	30
2.4	Measurement of Medium Resistance.....	37
2.5	Important Definitions.....	43
2.6	Measurement of High Resistance.....	44
	<i>Objective Brain Teasers</i> .....	47
	<i>Conventional Brain Teasers</i> .....	50

### CHAPTER 3

#### A.C. Bridges..... 53-81

3.1	Introduction to Bridge Measurement and A.C. Bridges.....	53
3.2	Measurement of Inductance.....	58
3.3	Wagner Earthing Device.....	71
3.4	Measurement of Frequency.....	72
3.5	Special Bridge Circuit.....	73
	<i>Objective Brain Teasers</i> .....	76
	<i>Conventional Brain Teasers</i> .....	79

### CHAPTER 4

#### Electromechanical Indicating Instruments..... 82-124

4.1	Introduction.....	82
4.2	Moving Iron (M.I.) Instruments.....	90
4.3	General Torque Equation of Moving Iron Instruments.....	90
4.4	Errors in Moving Iron Instruments.....	92
4.5	Electrodynamometer Type Instruments.....	99
4.6	Applications of Electrodynamometer Type Instruments.....	101
	<i>Objective Brain Teasers</i> .....	116
	<i>Conventional Brain Teasers</i> .....	119

### CHAPTER 5

#### Measurement of Power and Energy .... 125-161

5.1	Introduction.....	125
5.2	Measurement of Power.....	125

5.3	Electrodynamometer Wattmeters .....	126
5.4	Measurement of Energy .....	146
	<i>Objective Brain Teasers</i> .....	155
	<i>Conventional Brain Teasers</i> .....	160

## CHAPTER 6

### Cathode Ray Oscilloscope (CRO)..... 162-180

6.1	Introduction .....	162
6.2	Advantages Of CRO.....	162
6.3	Cathode Ray Tube (CRT) .....	163
6.4	Deflection Sensitivity of CRO.....	166
6.5	Graticule .....	168
6.6	Relation between Bandwidth and Rise Time .....	168
6.7	Lissajous Pattern .....	170
6.8	Phase Angle from the Lissajous Pattern .....	174
6.9	Special CRO .....	175
6.10	Probes of CRO .....	175
	<i>Objective Brain Teasers</i> .....	176

## CHAPTER 7

### Instrument Transformers..... 181-199

7.1	Introduction.....	181
7.2	Calculation of Ratio and Phase Angle Error of a CT	185

7.3	Characteristics of Current Transformers .....	189
7.4	Causes of Errors in CT .....	190
7.5	Methods to Reduce Errors in CT .....	191
7.6	Effect of Secondary Open Circuit .....	192
7.7	Construction of Current Transformer .....	192
7.8	Equivalent Circuit Diagram of a PT .....	194
7.9	Errors in a Potential Transformer .....	195
	<i>Objective Brain Teasers</i> .....	196
	<i>Conventional Brain Teasers</i> .....	197

## CHAPTER 8

### Digital Meters ..... 200-205

8.1	Digital Voltmeter (DVM) .....	200
8.2	Digital Frequency Meter.....	203

## CHAPTER 9

### Miscellaneous .....206-227

9.1	Potentiometer.....	206
9.2	Quality Factor Meter (Q Meter) .....	212
9.3	Flux Meter.....	218
9.4	Data Acquisition System (DAS) .....	219
9.5	Telemetry.....	222
	<i>Objective Brain Teasers</i> .....	225
	<i>Conventional Brain Teasers</i> .....	227



# Introduction to Measurements

---

Measurement and instrumentation systems have wide applications such as measurement of electrical and physical quantities like current, voltage, power, temperature, pressure, displacement etc.

The need for measurement arises when one wants to generate data for design or when one wants to propose a theory based on a set of measurement and instrumentation for commerce.

The measurement and instrumentation systems can also be used to locate things or events. Like employees present in a building, the epicenter of an earthquake. Sometimes, measurement systems are made a part of control system. One can observe the change in the field of measurement and instrumentation due to the introduction of new standards, and sensors.

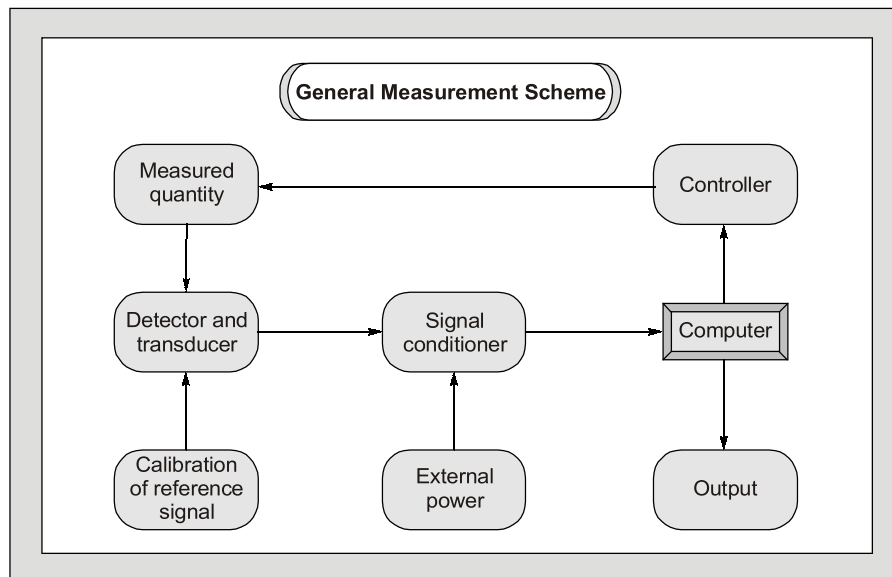

Equal importance has been provided to both theory as well as problems with illustrative examples after every topic. It has been tried to cover every topic so that even a beginner understands it easily to excel in the subject of measurement and instrumentation.



## 1.1 MEASUREMENTS AND IT'S SIGNIFICANCE

Measurement is the act, or the result, of a quantitative comparison between a given quantity of the same kind chosen as a unit. Measurement result is expressed by a pointer deflection over a predefined scale or a number representing the ratio between the unknown quantity and the standard. The device or instrument used for comparing the unknown quantity with the unity of measurement or a standard quantity is called a measuring instrument.

### Method of Measurement

#### Direct Measurement

- In this method, the measured or the unknown quantity is directly compared against a standard.
- This method of measurement sometimes produces human errors and hence gives inaccurate results.

#### Indirect Measurement

- This method of measurement is more accurate and more sensitive.
- These are more preferred over direct measurement.

### Mechanical, Electrical and Electronic Instruments

#### Mechanical

- This instruments are used for stable and static conditions:
- They are unable to respond rapidly to measurements of dynamic and transient conditions because of having moving parts that are bulky, heavy are rigid possessing high inertia.

#### Electrical

Electrical methods of indicating the output of detectors are more rapid than mechanical methods, but they are limited time response.

#### Electronic

These instruments require use of semiconductor devices. The response time of these instruments are extremely small as a very small inertia of electron is only involved. The sensitivity of these instruments is also very high. Faster response, lower weight, lower power consumption are some of the advantages of electronic instruments.

## 1.2 TYPES OF INSTRUMENTS

**Absolute Instruments :** These instruments give the magnitude of the quantity under measurement in terms of physical constants of the instruments, i.e., Tangent Galvanometer, Rayleigh’s current balance.

**Secondary Instruments :** In these type of instruments, the quantity being measured can only be measured by observing the output indicated by the instrument. These instruments are calibrated by comparing with an absolute instrument.

## 1.3 DEFLECTION AND NULL TYPE INSTRUMENTS

### Deflection Type

The deflection of the instrument provides a basis for determining the quantity under measurement, i.e., PMMC Ammeter, Electrodynamicometer and moving iron instruments. They are less accurate, less sensitive and have faster response.

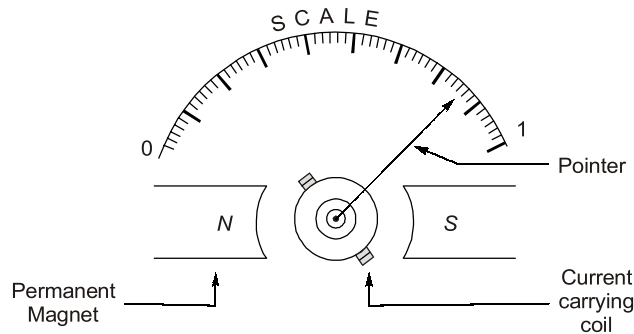

*Fig. : PMMC (Deflection Type Instrument)*

### Null Type Instruments

In null type instruments, a zero or null indication leads to determination of the magnitude of measured quantity. Null type instruments are more accurate, highly sensitive and are less suited for measurements under dynamic conditions than deflection type instruments.

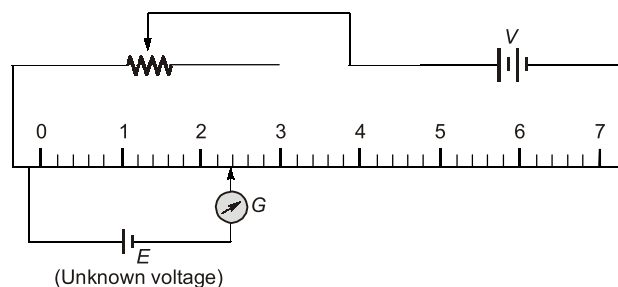

*Fig. : Null Type Instrument*

### Calibration

The calibration of all instruments is important since it affords the opportunity to check the instrument against a known standard and subsequently to find errors and accuracy. Calibration procedures involve a comparison of the particular instrument with a primary standard or, a secondary standard or, an instrument of known accuracy.

## Characteristics of Instrument and Measurement Systems

### Accuracy

- It is the closeness with which an instrument reading approaches the true value of the quantity being measured.
- The accuracy can be specified in terms of inaccuracy or limits of error.
- The best way to conceive the idea of accuracy is to specify it in terms of the true value of the quantity being measured.
- The accuracy of a measurement means conformity to truth.

### Precision

- It is a measure of the reproducibility of the measurements, i.e., given a fixed value of a variable, precision is a measure of the degree to which successive measurements differ from one another.
- The term "Precise" means clearly or sharply defined.
- Precision is used in measurements to describe the consistency or the reproducibility of results.
- Precision instruments are not guaranteed for accuracy.

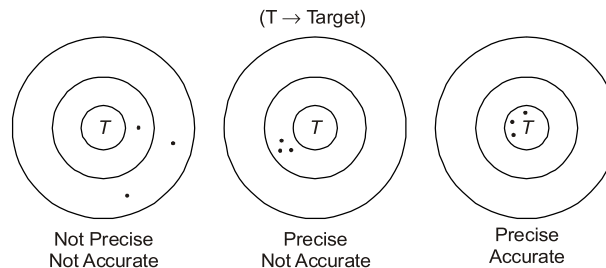

- Precision depends upon number of significant figures.
- The more are significant figures the more is precision.
- Significant figures convey actual information regarding the magnitude and the measurement precision of a quantity.

**Example:** 302 A (Number of significant figures = 3)

302.10 V (Number of significant figures = 5)

0.000030  $\Omega$  (Number of significant figures = 2)

#### EXAMPLE : 1.1

In calculating voltage drop, a current of 4.37 A is recorded in a resistance of 31.27  $\Omega$ . Calculate the voltage drop across the resistor to the appropriate number of significant figures.

#### Solution :

Current,

$$I = 4.37 \text{ A (3 significant figures)}$$

Resistance,

$$R = 31.27 \Omega \text{ (4 significant figures)}$$

Voltage drop,

$$V = IR = 4.37 \times 31.27 = 136.6499 \text{ volt}$$

Since number of significant figures used in multiplication is 3.

So answer can be written only to a maximum of three significant figures, i.e.,  $V = 137$

**NOTE:** 248 volt  $\Rightarrow$  0.000248 MV

248.0 volt  $\Rightarrow$  More precised than other two.

**EXAMPLE : 1.2**

Assertion (A) : A precision instrument is always accurate.

Reason (R) : A precision instrument is one where the degree of reproducibility of the measurements is very good.

- (a) Both A and R are true and R is the correct explanation of A
- (b) Both A and R are true but R is NOT the correct explanation of A
- (c) A is true but R is false
- (d) A is false but R is true

**Solution : (d)**

Statement (A) is false because accuracy and precision are not interrelated. Accuracy of an instrument is its closeness to the true value.

Statement (R) is correct definition of precision.

**Linearity**

- If the output is proportional to input then, the instrument is called linear.
- Non-linear behaviour of an instrument doesn't essentially lead to inaccuracy.
- Most of the time it is necessary that measurement system component should have linear characteristics. For example, the resistance used in a potentiometer should vary linearly with displacement of the sliding contact in order that the displacement is directly proportional to the sliding contact voltage. Any departure from linearity will result in error in the reading of system.

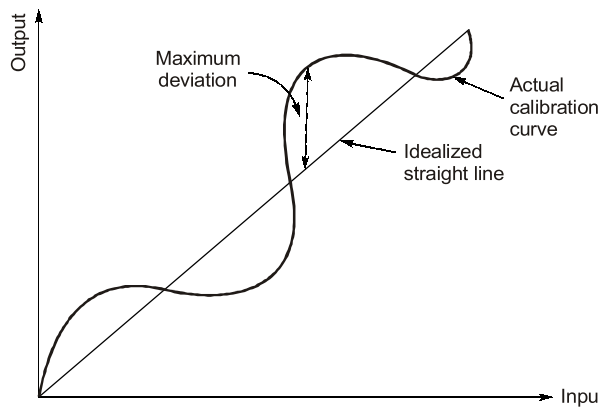

**Fig. :** Linearity with respect to actual calibration curve and idealized straight line

**Drift**

Drift is the gradual shift in the indication of the instrument over a period of time. Drift is a undesirable quality in an instruments that is why instruments are properly guarded against it.

**Types of Drifts**

1. **Zero Drift** : It is the consistent shift across all the measured values. A change in the zero value is responsible for zero drift.
2. **Span Drift** : It is the proportional increasing or decreasing shift of the measured value away from the calibrated values as the measured values increases or decreases.

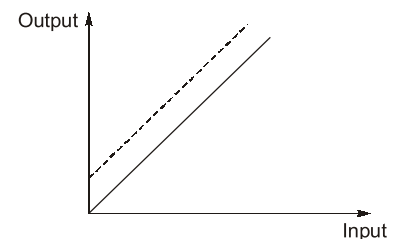

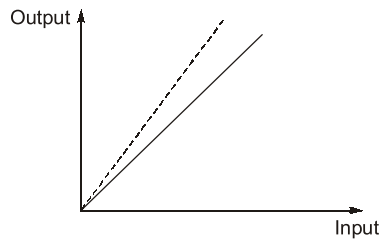

3. **Zonal Drift** : It occurs when only a particular span of measured values is shifted away from the calibrated values. All other measured values remains unaffected.

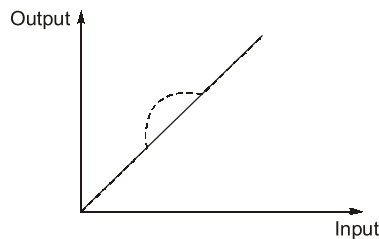

4. **Combined Drift** : When multiple drifts are present at once then combined drift occurs.

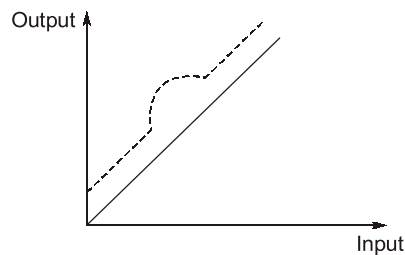

### Reproducibility

It is the degree of closeness with which a given value may be repeatedly measured. It may be specified in terms of units for a given period of time.

### Static Sensitivity

- The “static sensitivity” of an instrument is the ratio of the magnitude of the output signal or response to the magnitude of input signal or the quantity being measured. It's units are mm/mA; per volts etc. depending upon type of input and output.
- Sometimes the static sensitivity is expressed as the ratio of the magnitude of the measured quantity to the magnitude of the response.

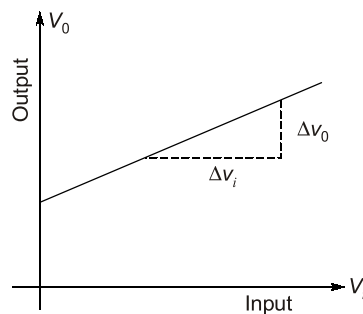

Fig. : Sensitivity

$$\text{Static Sensitivity} = \frac{\text{Small change in output}}{\text{Small change in input}} = \frac{\Delta V_o}{\Delta V_i}$$

- The sensitivity of an instrument should be high and therefore, instrument should not have a range greatly exceeding the value to be measured.

$$\text{Deflection Factor} = \frac{1}{(\text{Static Sensitivity})}$$

**Resolution or Discrimination**

- The small measurable input change that can be measured by the instrument is called resolution or discrimination.
- If the input is slowly increased from some arbitrary (non-zero) input value, it will again be found that output doesn't change at all until a certain increment is exceeded. This increment is called resolution.

**EXAMPLE : 1.3**

A digital voltmeter has a read-out range from 0 to 9,999 counts. If the full scale reading is 9.999 V, then the resolution of the instrument in mV, is \_\_\_\_.

**Solution :**

Resolution of instrument = 1 count in 9,999

$$\text{Resolution} = \frac{1}{9999} \text{ count} = \frac{1}{9999} \times 9.999 = 10^{-3} \text{ volt} = 1 \text{ mV}$$

**Dead Time & Dead Zone**

**Dead Time:** The time required for the measurement to begin to respond to the changes in the measurand is known as dead time. It is the time after which the instrument begins to respond after the measured quantity has been changed.

**Dead Zone:** Dead zone is the largest change of input quantity for which there is no output of the instrument.

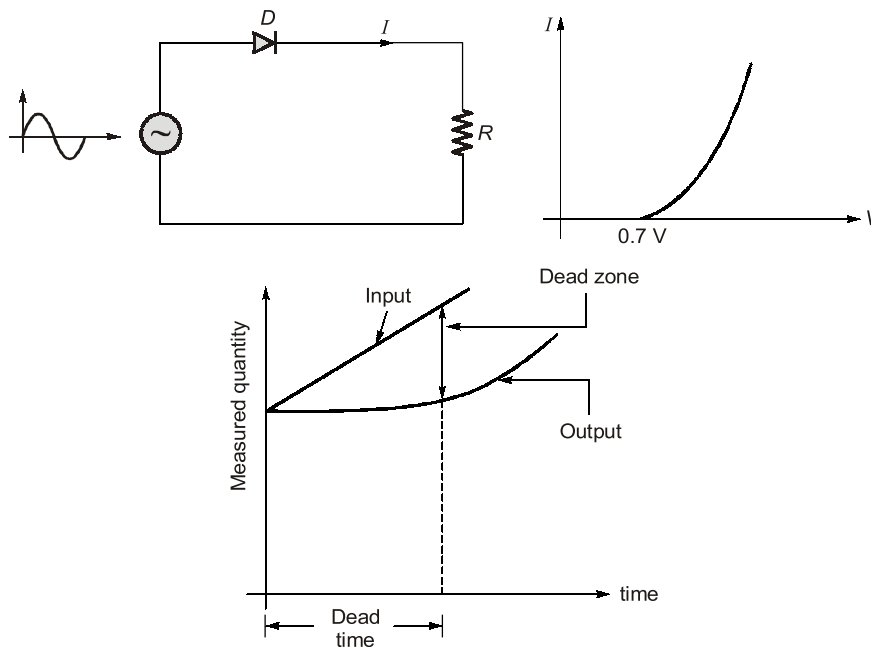

**Fig. : Dead Zone and Dead Time**

**Signal to Noise Ratio (S/N)**

- Noise is an unwanted signal superimposed upon the signal of interest thereby causing a deviation of the output from its expected value.
- The ratio of powers of desired signal to the unwanted noise is called signal to noise ratio and is expressed as

$$\frac{S}{N} = \frac{\text{Signal Power}}{\text{Noise Power}}$$

- In any measurement system, it is desired to have a large signal-to-noise ratio. This can be achieved by increasing the signal level without increasing the noise level or decreasing the noise level with some suitable technique.

**Repeatability**

It is the repetition of reading of an instrument from a given set of reading.

**1.4 ERRORS IN MEASUREMENTS AND THEIR ANALYSIS**

Measurements done in a laboratory or at some other place always involve errors. No measurement is free from errors. If the precision of the equipment is adequate, no matter what its accuracy is, a discrepancy will always be observed between two measured results.

**True Value**

The true value of quantity to be measured may be defined as the average of an infinite number of measured values when the average deviation due to various contributing factors tends to zero.

**Guarantee Errors**

The accuracy and precision of an instrument depends upon its design, the material used and the workmanship that goes into making the instrument. Components are guaranteed to be within a certain percentage of the rated value. Thus, the manufacturer has to specify the deviations from the "nominal value" of a particular quantity. The limits of these deviations from the specified value are defined as "**Limiting Errors**" or "**Guarantee Errors**".

For example, the magnitude of resistance of a resistor is 200  $\Omega$  with a limiting error of  $\pm 10 \Omega$ . The magnitude of the resistance will be between the limits

$$R = 200 \pm 10 \Omega \quad \text{or} \quad R \geq 190 \Omega \quad \text{and} \quad R \leq 210 \Omega$$

Hence, the manufacturer guarantees that the value of resistance of the resistor lies between 190  $\Omega$  and 210  $\Omega$ .

**Absolute (Relative) Limiting Error**

The relative (fractional) error is defined as the ratio of the error to the specified (nominal) magnitude of a quantity.

$$\text{Relative limiting error, } \varepsilon_r = \left( \frac{\text{Measured value} - \text{True value}}{\text{True value}} \right) \times 100$$

or 
$$\% \varepsilon_r = \left( \frac{\text{Actual value} - \text{Nominal value}}{\text{Nominal Value}} \right) \times 100$$

or 
$$\% \varepsilon_r = \left( \frac{A_m - A_T}{A_T} \right) \times 100 \quad \begin{cases} A_m = \text{Measured value} \\ A_T = \text{True value} \end{cases}$$

Now,  $\% \epsilon_r = \frac{A_m - A_T}{A_T}$  or  $\frac{A_m}{A_T} = 1 + \epsilon_r$  or  $\boxed{\frac{A_T}{A_m} = \frac{1}{1 + \epsilon_r}}$

$$\boxed{A_T = \left( \frac{1}{1 + \epsilon_r} \right) A_m}$$

Here,  $\boxed{\frac{1}{1 + \epsilon_r} = \text{Correction factor}}$

**NOTE:** Nominal value = True value and Actual value = Measured value

**EXAMPLE : 1.4**

The dead zone in a certain pyrometer is 0.125 percent of span. The calibration is 400°C to 1000°C. What temperature change might occur before it is detected?

- (a) 0.25°C      (b) -0.50°      (c) 1.25°C      (d) 0.75°C

**Solution : (d)**

$$\text{Span} = 1000 - 400 = 600^\circ \text{C}$$

$$\therefore \text{Dead zone} = 0.125\% \text{ of span} = \frac{0.125}{100} \times 600 = 0.75^\circ \text{C}$$

Hence, a change of 0.75°C must occur before it is detected.

**Combination of Quantities with Limiting Errors**

When two or more quantities, each having a limiting error, are combined, it is advantageous to be able to compute the limiting error of the combination.

**1. Sum or Difference of Two or More Quantities**

Let  $x_1 = a \pm \epsilon_{r1}; \quad x_2 = b \pm \epsilon_{r2}; \quad x_3 = c \pm \epsilon_{r3}$

$\therefore x = x_1 + x_2 + x_3 \quad \text{OR} \quad x = -x_1 - x_2 - x_3$

So,  $x = \pm (x_1 + x_2 + x_3)$

Relative limiting error in  $x$  is given by

$$\boxed{\epsilon_x = \pm \left( \frac{a}{a+b+c} \cdot \epsilon_{r1} + \frac{b}{a+b+c} \cdot \epsilon_{r2} + \frac{c}{a+b+c} \cdot \epsilon_{r3} \right)}$$

( $\epsilon_x$  = worst possible error)

**EXAMPLE : 1.5**

Two PMMC ammeters are connected individually in series with armature winding and field winding of a dc shunt motor. Ammeter connected in series with armature and field windings show reading along with % limiting errors  $I_a = 96.5 \text{ A} \pm 2\%$  and  $I_f = 4.5 \text{ A} \pm 1\%$  respectively. The value of percentage limiting error in total current will be  $\pm$  \_\_\_\_\_ %. (upto 3 decimal places)

**Solution :**

Limiting error in total

$$\frac{\delta x}{X} = \left[ \frac{x_1}{X} \frac{\delta x_1}{x_1} + \frac{x_2}{X} \frac{\delta x_2}{x_2} \right]$$

where,

$$\text{Armature winding current, } x_1 = 96.5 \text{ A and } \frac{\delta x_1}{x_1} = \pm 2\% \text{ (or) } \pm 0.02$$

$$\text{Fielding winding current, } x_2 = 4.5 \text{ A and } \frac{\delta x_2}{x_2} = \pm 1\% \text{ (or) } \pm 0.01$$

$$\text{Total current drawn, } X = x_1 + x_2 = 101 \text{ A}$$

$$\frac{\delta x}{X} \% = \pm \left[ \frac{96.5}{101} \times 2\% + \frac{4.5}{101} \times 1\% \right] = [1.911 + 0.045] = 1.956\%$$

## 2. Multiplication or Division Terms

$$\text{Let, } x = \frac{x_1 x_2}{x_3} \text{ or } \frac{x_2 x_3}{x_1} \text{ or } x_1 x_2 x_3 \text{ or } \frac{x_1}{x_2 x_3}$$

$$\text{Then, relative limiting error is } \boxed{\epsilon_x = \pm(\epsilon_{r1} + \epsilon_{r2} + \epsilon_{r3})}$$



$$\text{When, } x = \frac{x_1 x_2}{x_2 + x_3} \text{ or } \frac{x_1}{x_2 + x_3} \text{ or } \frac{x_1 x_2}{x_2 - x_1}$$

Then, multiplication or division form is not applicable for finding relative limiting error.

### EXAMPLE : 1.6

Resistance of the circuit was calculated using current flowing through circuit and power consumed in the circuit. If the limiting error in current and power are  $\pm 2\%$  and  $\pm 4\%$  respectively. Find the value of limiting error in the resistance?

**Solution :**

$$\text{Limiting error in current} = \pm 2\%$$

$$\text{limiting error in power} = \pm 4\%$$

$$P = I^2 R$$

$$\ln P = 2 \ln I + \ln R$$

$$\ln R = \ln P - 2 \ln I$$

Differentiating both sides, we get

$$\frac{\delta R}{R} = \frac{\delta P}{P} - 2 \frac{\delta I}{I}$$

$$\frac{\delta I}{I} = \pm 2\% = 0.02$$

$$\frac{dP}{P} = \pm 4\% = 0.04$$

$$\text{Limiting error, } \frac{dR}{R} = \frac{\delta P}{P} \pm \frac{2\delta I}{I} = 0.04 \pm 0.04 = 0.08 = 8\%$$

## 3. Power of a Factor

$$\text{Let, } x = x_1^m \cdot x_2^n \cdot x_3^p \text{ or } \frac{x_1^m x_2^n}{x_3^p} \text{ or } \frac{x_1^m}{x_2^n x_3^p}$$

$$\text{Then, relative limiting error is } \epsilon_r = \pm(m\epsilon_{r1} + n\epsilon_{r2} + p\epsilon_{r3})$$



When  $x$  is of the form  $\frac{x_1^m}{x_2^n + x_3^p}$  or  $\frac{x_1^m + x_2^n}{x_3^p}$

then, above method is not applicable for finding relative limiting error.

**4. Special Case**

Resistance in parallel:

Let,  $R_1 = 10 \pm 10\%$  (Range = 9  $\Omega$  to 11  $\Omega$ )

and  $R_2 = 20 \pm 5\%$  (Range = 19  $\Omega$  to 21  $\Omega$ )

Equivalent resistance of parallel combination is  $R = \frac{R_1 R_2}{R_1 + R_2}$

True value,  $R = \frac{10 \times 20}{10 + 20} = 6.66 \Omega = R_T$

Resistance in lower range,  $R_L = \frac{R_1 R_2}{R_1 + R_2} = \frac{9 \times 19}{9 + 19} = 6.107 \Omega = \text{Measured value in low range} = L_m$

Resistance in higher range,  $R_H = \frac{11 \times 21}{11 + 21} = 7.21875 \Omega = \text{Measured value for high range} = H_m$

$$\text{Error in low range (for low value)} = \% \epsilon_r = \left( \frac{L_m - R_T}{R_T} \right) \times 100$$

$$\text{Error in high range (for high value)} = \% \epsilon_r = \left( \frac{H_m - R_T}{R_T} \right) \times 100$$

For present case,

Error in low range;  $\% \epsilon_r = \left( \frac{6.10 - 6.66}{6.66} \right) \times 100 = -8.4 \%$

Error in high range;  $\% \epsilon_r = \left( \frac{7.2187 - 6.66}{6.66} \right) \times 100 = 8.38 \%$

**5. Uncertainty Error**

The uncertainty analysis in measurements when many variables are involved is done on the same basis as is done for error analysis when the result are expressed as standard deviations or probable errors.

Let  $x = f(x_1, x_2, \dots, x_n)$

$w_{x_1}, w_{x_2}, \dots, w_{x_n}$  be the uncertainties of  $x_1, x_2, \dots, x_n$  respectively. Then, uncertainty of  $x$  is given by

$$w_x = \sqrt{\left( \frac{\partial x}{\partial x_1} \right)^2 \cdot w_{x_1}^2 + \left( \frac{\partial x}{\partial x_2} \right)^2 \cdot w_{x_2}^2 + \left( \frac{\partial x}{\partial x_3} \right)^2 \cdot w_{x_3}^2 + \dots + \left( \frac{\partial x}{\partial x_n} \right)^2 \cdot w_{x_n}^2}$$

**EXAMPLE : 1.7**

Two resistors  $R_1$  and  $R_2$  are connected in series. The value of resistance are

$$R_1 = 100.0 \pm 0.1 \Omega, R_2 = 50 \pm 0.03 \Omega$$

If the error in  $R_1$  or  $R_2$  has to be considered as standard deviation then find the standard deviation in series equivalent resistance?



## OBJECTIVE BRAIN TEASERS

- Q1** Which of the following error is likely to occur in bridge method of measurement?
1. Residual error
  2. Frequency and waveform error
  3. Leakage and eddy current error
- (a) 1 only                      (b) 2 only  
(c) 1 and 2 only              (d) 1, 2 and 3
- Q2** A utility type voltmeter with an accuracy of  $\pm 3\%$  of full scale (at  $25^\circ\text{C}$ ) is used on 300 V scale to measure 230 V. What will be the possible percentage error and what range will the actual voltage fall within if the instrument reads 200 V?
- (a) 3.9%, 200 V              (b) 3.9%, 191-209 V  
(c) 7.6%, 221-239 V        (d) 7.6%, 200 V
- Q3** In the circuit given in the figure, the limiting error in the power dissipation ' $I^2R$ ' in the resistor  $R$  is

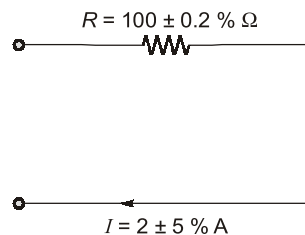

- (a) 1.2%                      (b) 5.2%  
(c) 10.2%                    (d) 25.2%
- Q4** A zero to 300 V voltmeter has a guaranteed accuracy of 1% full scale reading. The voltage measured by the instrument is 83 V. The percentage limiting error is
- (a) 0.95                      (b) 1.81  
(c) 3.62                      (d) 4.85
- Q5** Five Students made the following readings on a very accurate voltmeter which reads 2.13 V, 3.15 V, 2.97 V, 3.10 V and 2.99 V. What is the most probable value of the voltage?
- (a) 3.066 V                  (b) 3.12 V  
(c) 2.99 V                    (d) 2.97 V
- Q6** The measurement of a quantity :
- (a) is an act of comparison of an unknown quantity with another quantity.

- (b) is an act of comparison of an unknown quantity with a known quantity whose accuracy may be known or may not be known.
- (c) is an act of comparison of an unknown quantity with a predefined acceptable standard which is accurately known.
- (d) none of the above

- Q7** A null type of instrument as compared to a deflection type instrument has
- (a) a high accuracy        (b) a lower sensitivity  
(c) a faster response        (d) all of these
- Q8** In measurement systems, which of the following are undesirable static characteristics?
- (a) Sensitivity and accuracy  
(b) Drift, static error and dead zone  
(c) Reproducibility and non-linearity  
(d) Drift, static error, dead zone and non-linearity
- Q9** A set of reading has a wide range and therefore it has:
- (a) low precision            (b) high precision  
(c) low accuracy            (d) high accuracy
- Q10** The following are the desirable dynamic characteristics of a measurement system :
- (a) fast response, fidelity, measuring lag and dynamic error  
(b) fast response and measuring lag  
(c) fidelity and measuring lag  
(d) fast response and fidelity
- Q11** A 0-10 A ammeter has a guaranteed accuracy of 1.5% of full scale reading. The current measured by the instrument is 2.5 A. The percentage limiting error in the measurement is  $\pm$ \_\_\_\_\_ %.
- Q12** In the Permanent Magnet Moving Coil (PMMC) instruments, damping is provided by
- (a) The coil spring attached to the moving coil.  
(b) The aluminium frame to the moving coil.  
(c) Damping vane in the air tight chamber.  
(d) Eddy current disk.
- Q13** A PMMC instrument is spring controlled. The control spring stiffness decreases by 0.02 percent per degree Celsius rise in temperature and magnetic field strength decreases by 0.01 percent

per degree Celsius rise in temperature. If the rise in temperature is 10° C, the instrument's reading

- (a) decreases by 0.1 percent.
- (b) increases by 0.2 percent.
- (c) increases by 0.1 percent.
- (d) decreases by 0.2 percent.

**Q.14** The damping method used in horizontally mounted moving iron instrument is

- (a) Eddy current damping
- (b) Electro magnetic damping
- (c) Fluid friction damping
- (d) Air friction damping

**Q.15** A power transformer was tested to determine losses and efficiency. The input power was measured as 3650 W and delivered output power was 3385 W with each reading in doubt by ±10 W. The percentage uncertainty in the losses of the transformer is

- (a) ±4.30%
- (b) ±5.34%
- (c) ±2.24%
- (d) ±10.24%

**Q.16** In a gravity controlled instrument the controlling weight is 0.005 kg and acts at distance of 2.4 cm from the axis of the moving system. The deflection in degrees corresponding to deflecting torque of  $1.05 \times 10^{-4}$  Kg-m is

**Q.17** The torque of an ammeter varies as the square of the current through it. If a current of 10 A produces a deflection of 90°. The deflection for a current of 5 A when the instrument is gravity controlled, is \_\_\_\_\_ degrees.

**Q.18** The value of capacitance of a capacitor is specified as  $1 \mu\text{F} \pm 5\%$  by the manufacturer. The value of limits between which the value of capacitance is guaranteed will be

- (a) 0.98  $\mu\text{F}$  to 1.02  $\mu\text{F}$
- (b) 0.95  $\mu\text{F}$  to 1.05  $\mu\text{F}$
- (c) 0.80  $\mu\text{F}$  to 1.20  $\mu\text{F}$
- (d) 0.90  $\mu\text{F}$  to 1.10  $\mu\text{F}$

**Q.19** A temperature range from -20°C to 50°C is to be measured with a resolution of 0.2°C. The minimum bits required to get a matching dynamic range of the temperature sensor will be

- (a) 8
- (b) 4
- (c) 6
- (d) 9

**Q.20** In a ramp type digital voltmeter, the ramp voltage falls from 4 V to 0 V in 10 msec and duration for an applied voltage and the number of pulses counted is 10000. The value of oscillator frequency (in MHz) for above counter will be \_\_\_\_.

**Q.21** The input impedance of a CRO is equivalent to a 1 M $\Omega$  resistance in parallel with 45 pF capacitance. It is used with a compensated 10 : 1 attenuation probe. The effective input capacitance at the probe tip is

- (a) 4.5 pF
- (b) 5 pF
- (c) 45 pF
- (d) 450 pF

**ANSWER KEY**

- 1. (d)    2. (b)    3. (c)    4. (c)    5. (a)
- 6. (c)    7. (a)    8. (d)    9. (a)    10. (d)
- 11. (6)    12. (b)    13. (c)    14. (d)    15. (b)
- 16. (61)    17. (14.5)    18. (b)    19. (d)    20. (1)
- 21. (a)

**HINTS & EXPLANATIONS**

**1. (d)**

The various errors occurring in bridge method of measurement are (which we will see in later chapters):

- ⇒ Frequency error
- ⇒ Waveform error
- ⇒ Eddy Current error
- ⇒ Leakage Current error
- ⇒ Residual error

**2. (b)**

Accuracy = ± 3% of full scale which corresponds to ± 9 V. So, range of reading for

$$200 \text{ V} = (200 \pm 9) \text{ V} = 191 - 209 \text{ V}$$

**3. (c)**

$$\begin{aligned} \% \epsilon &= 2 \times \epsilon_I + \epsilon_R \\ &= 2 \times 5 + 0.2 = 10.2\% \end{aligned}$$

$$= \sin^{-1} \left[ \left( \frac{5}{10} \right)^2 \times 1 \right]$$

$$= \sin^{-1} 0.25 = 14.5^\circ$$

**18. (b)**

We know,  $A_t = A_a(1 \pm \epsilon_r) = 1(1 \pm 0.05)$   
 $= 0.95 \mu\text{F to } 1.05 \mu\text{F}$

**19. (d)**

Given : temperature range  $(50^\circ - (-20^\circ)) = 70^\circ\text{C}$   
 Resolution =  $0.2^\circ\text{C}$

Resolution relative to range =  $\frac{0.2}{70} = 0.00286$

For  $N$  bit ADC, Resolution =  $\frac{1}{2^N - 1} = 0.00286$

$2^N = 350 \Rightarrow N \simeq 9$

**20. (1)**

The number of pulses counted by ramp type DVM,

$$n = \frac{t_r}{t_{clk}}$$

$t_r = 10 \text{ msec}; n = 10000$

$n = t_r \times f_{clk}$

Oscillator frequency,

$$f_{clk} = \frac{10000}{10 \times 10^{-3}} = 1 \text{ MHz}$$

**21. (a)**

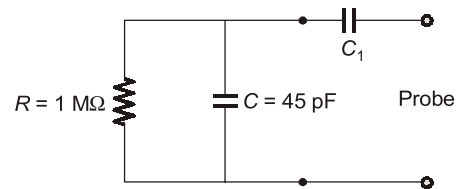

So effective capacitance

$$C_{eq} = \frac{C_1 \cdot C}{C_1 + C} = \frac{C}{10}$$

$$\Rightarrow 10C_1 = C_1 + C \Rightarrow C_1 = \frac{C}{9} = \frac{45}{9} = 5 \text{ pF}$$

The effective input capacitance at probe tip

$$= \frac{C_1 C}{C_1 + C} = \frac{45 \times 5}{50} = 4.5 \text{ pF}$$



**CONVENTIONAL BRAIN TEASERS**

**Q.1** Find the uncertainty in the measurement of power dissipated by resistor if the current flowing through the resistor is 5 A and the voltage across the resistor is 200 V and the uncertainty of the ammeter is 0.2 A and the voltmeter is 1.5 V. Find the uncertainty of the power.

**1. (Sol)**

We know that,

$$P = VI$$

∴

$$\frac{\delta P}{\delta V} = I = 5 \text{ A}$$

$W_V = 1.5 \text{ V}$

(given)

$$\frac{\delta P}{\delta I} = V = 200 \text{ V,}$$

$W_I = 0.2 \text{ A}$

∴ Uncertainty in the measurement of power is given by :